



HIGH-STRENGTH STRUCTURAL
BOLTING ASSEMBLIES
FOR PRELOADING
BS EN 14399-7:2018
HR COUNTERSUNK
BOLT & NUT ASSEMBLIES



EN14399-1
Cert No:
0038/CPR/4006773/B



BAPPP

Group of Companies

Dimensions For Bolts

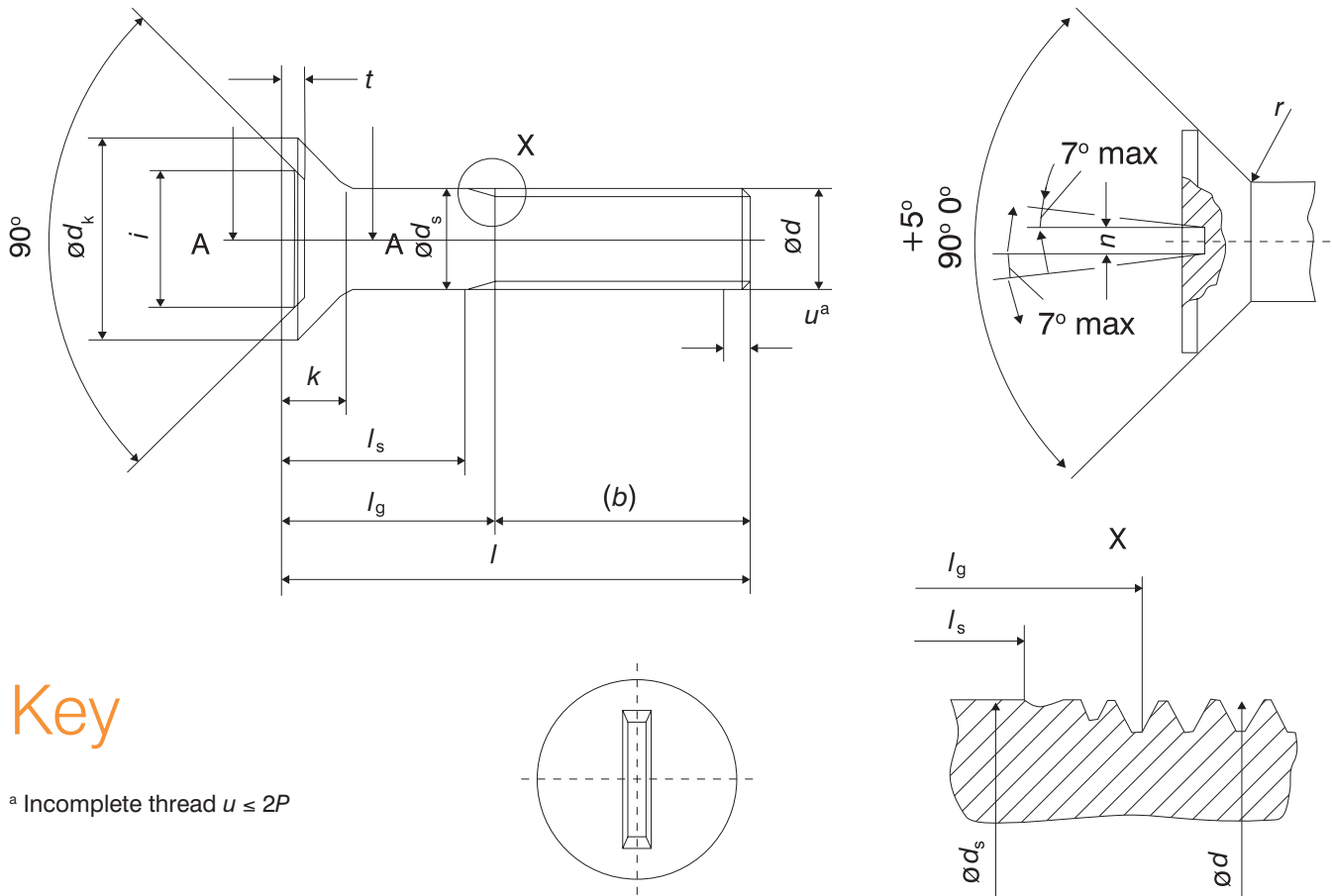

Key

^a Incomplete thread $u \leq 2P$

Thread d		M12	(M14) ^a	M16	(M18) ^a	M20	M22	M24	M27	M30	M36
P^b		1,75	2	2	2,5	2,5	2,5	3	3	3,5	4
b (ref.)	^c	30	34	38	42	46	50	54	60	66	78
	^d	-	40	44	48	52	56	60	66	72	84
	^e	-	-	-	-	65	69	73	79	85	97
d_s	max.	12,70	14,70	16,70	18,70	20,84	22,84	24,84	27,84	30,84	37,00
	min.	11,30	13,30	15,30	17,30	19,16	21,16	23,16	26,16	29,16	35,00
d_k	max.	24,00	28,00	32,00	36	40	44	48	54	60,0	72,0
	min.	23,16	27,16	31,16	35	39	43	47	53	58,8	70,8
i	max.	16,5	19,5	22,5	25,5	28,5	30,5	33,5	37,5	42,5	50,5
	min.	15,5	18,5	21,5	24,5	27,5	29,5	32,5	36,5	41,5	49,5
k	nom.	8,00	9,00	10,00	12,0	13,0	14,0	16,0	17,5	19,50	23,00
	max. ^f	8,75	9,75	10,75	12,9	13,9	14,9	16,9	18,4	20,55	24,05
	min. ^g	7,25	8,25	9,25	11,1	12,1	13,1	15,1	16,6	18,45	21,95
r	max.	1,6	1,6	1,6	2	2	2	2	2,5	2,5	2,5
	min.	1,2	1,2	1,2	1,5	1,5	1,5	1,5	2	2	2
n	max.	3,0	3,0	3,0	3,5	3,5	3,5	3,5	3,5	4,0	4,0
	min.	2,5	2,5	2,5	3,0	3,0	3,0	3,0	3,0	3,5	3,5
t	max.	4,5	4,5	4,5	5,0	5,0	5,0	5,0	5,0	5,5	5,5
	min.	3,0	3,0	3,0	3,5	3,5	3,5	3,5	3,5	4,0	4,0

^a Non-preferred sizes.

^b P is the pitch of thread.

^c For lengths $l/\text{nom} \leq 125$ mm.

^d For lengths 125 mm $< l/\text{nom} \leq 200$ mm.

^e For lengths $l/\text{nom} > 200$ mm.

^f k_{max} includes the height of embossed marking, if any.

^g k_{min} excludes the height of embossed marking, if any.

Specifications For Bolts & Reference Standards

Material		Steel
General requirements		BS EN 14399-1 and BS EN 14399-2
Thread	Tolerance	6g ^a
	International Standards	ISO 261, ISO 965-2
Mechanical properties	Property class	8.8 or 10.9
	European Standard	BS EN ISO 898-1
Tolerances	Product grade	C except dimension <i>r</i> . Tolerance for lengths ≥ 160 mm $\pm 4,0$ mm
	International Standard	BS EN ISO 4759-1
Finish - Coating ^b	Uncoated	as processed ^c
	hot dip galvanized	BS EN ISO 10684
	Others	to be agreed ^d
Surface integrity	Limits for surface discontinuities are covered in BS EN 26157-1.	
Acceptability	For acceptance procedure, see BS EN ISO 3269.	
^a The tolerance class specified applies to bolts without or before any coating. Hot-dip galvanized bolts are intended for assembly with nuts tapped oversize to 6AZ.		
^b Attention is drawn to the need to consider the risk of hydrogen embrittlement in the case of bolts of property class 10.9, when selecting an appropriate surface treatment process (e.g. cleaning and coating), see the relevant coating standards.		
^c "As processed" means the normal finish resulting from manufacture with a light coating of oil.		
^d Other coatings may be negotiated between the purchaser and the manufacturer provided they do not impair the mechanical properties or the functional characteristics. Coatings of cadmium or cadmium alloy are not permitted.		

Marking of Bolts

High-strength structural countersunk bolts according to this document shall be marked with:

- property class marking in accordance with BS EN ISO 898-1 and the letters HR.
- the identification mark of the manufacturer of the assembly.

It is permissible for the marking to be either embossed or indented on the top surface of the head.

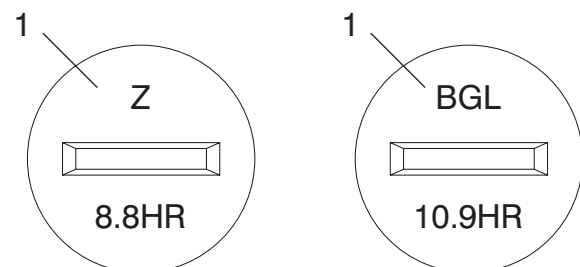

Key

1 Identification mark of the manufacturer of the Assembly

Dimensions For Nuts

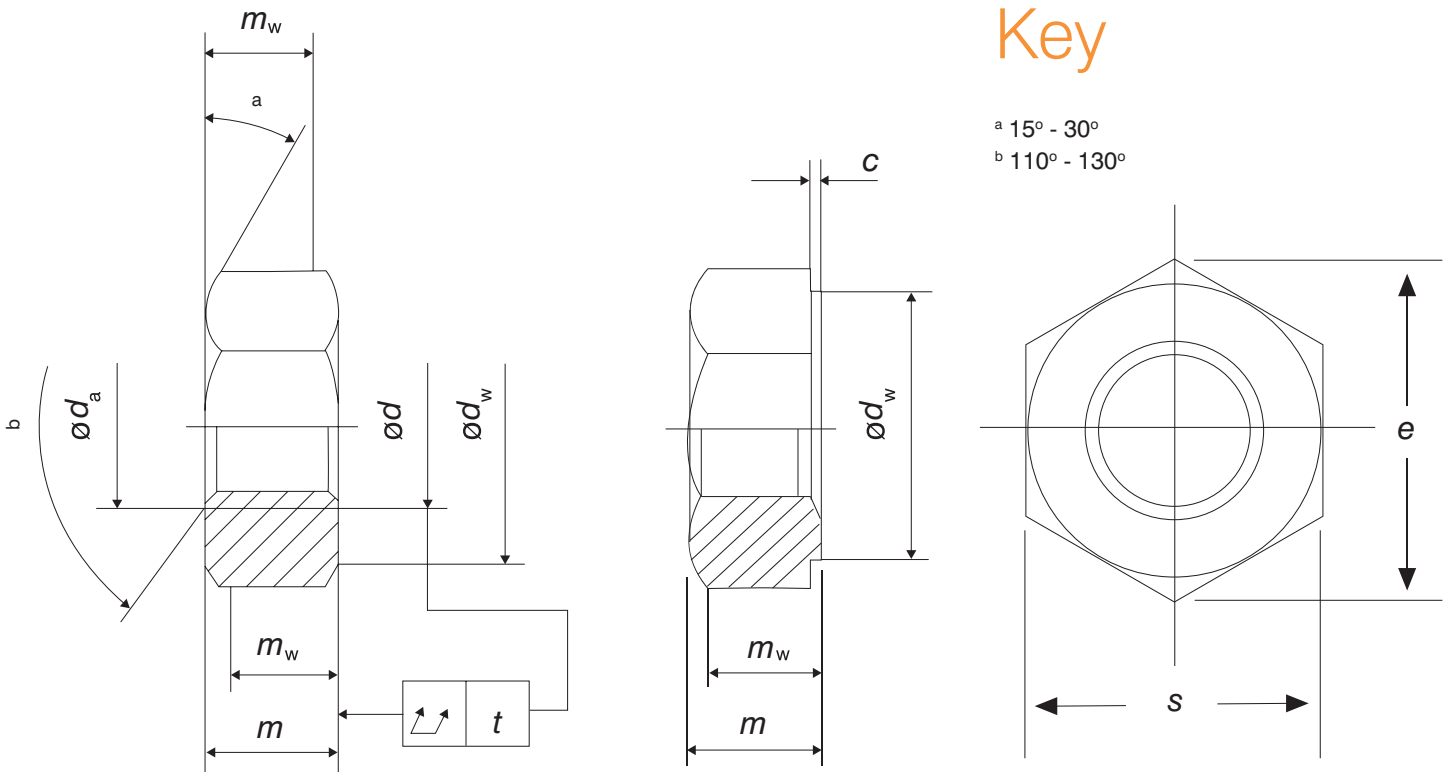

Thread d		M12	(M14) ^a	M16	(M18) ^a	M20	M22	M24	M27	M30	M36
P^b		1,75	2	2	2,5	2,5	2,5	3	3	3,5	4
d_a	max.	13	15,1	17,3	19,5	21,6	23,7	25,9	29,1	32,4	38,9
	min.	12	14	16	18	20	22	24	27	30	36
d_w	max.	^c									
	min.	20,1	21,86	24,9	27,70	29,5	33,3	38,0	42,8	46,6	55,9
e	min.	23,91	27,12	29,56	32,95	35,03	39,55	45,20	50,85	55,37	66,44
m	max.	10,8	12,8	14,8	15,8	18	19,4	21,5	23,8	25,6	31
	min.	10,37	12,1	14,1	15,1	16,9	18,1	20,2	22,5	24,3	29,4
m_w	min.	8,3	9,7	11,3	12,1	13,5	14,5	16,2	18,1	19,5	22,4
c	max.	0,8	0,8	0,8	0,8	0,8	0,8	0,8	0,8	0,8	0,8
	min.	0,4	0,4	0,4	0,4	0,4	0,4	0,4	0,4	0,4	0,4
s	max.	22	24	27	30	32	36	41	46	50	60
	min.	21,16	23,16	26,16	29,16	31	35	40	45	49	58,8
t		0,38	0,42	0,47	0,52	0,58	0,63	0,72	0,80	0,87	1,05

^a Non-preferred sizes.

^b P is the pitch of thread.

^c d_w max = actual

For coated nuts the above dimensions apply prior to coating.

Specifications For Nuts & Reference Standards

Material	Steel			
General requirements	BS EN 14399-1 and BS EN 14399-2			
Thread	Coating of the bolt	Uncoated	Hot dip galvanized	Others
	Tolerance class of the nut	6H	6AZ	6H ^a
	International Standards	ISO 261, ISO 965-2	ISO 261, ISO 965-5	ISO 261, ISO 965-2, ISO 965-5
Mechanical properties	Property class	8 ^b or 10 ^b		
	European Standard	BS EN ISO 898-2		
Tolerances	Product grade	B except for dimensions <i>m</i> and <i>c</i>		
	European Standard	BS EN ISO 4759-1 ^c		
Finish - Coating	Uncoated	as processed ^d		
	Hot dip galvanized	BS EN ISO 10684		
	Others	to be agreed ^e		
Surface integrity		Limits for surface discontinuities as specified in BS EN ISO 6157-2.		
Acceptability		For acceptance procedure, see BS EN ISO 3269.		
^a For other coatings that need an increased fundamental deviation and according to the relevant standard, oversize tapped nuts with a thread tolerance class up to 6AZ may be used.				
^b For mechanical properties other than those specified in BS EN ISO 898-2, see 4.3, Table 6 for proof load values and Table 7 for hardness values.				
^c Except tolerance on perpendicularity of bearing face, see tolerance <i>t</i> in Table 4.				
^d "As processed" means the normal finish resulting from manufacture with a light coating of oil.				
^e Other coatings may be negotiated between the purchaser and the manufacturer provided they do not impair the mechanical properties or the functional characteristics. Coatings of cadmium or cadmium alloys are not permitted.				

Marking of Nuts

High-strength structural nuts according to this document shall be marked with:

- property class marking in accordance with BS EN ISO 898-2 and the letters HR.
- the identification mark of the manufacturer of the bolting assembly.

The marking shall be indented on one of the bearing faces of chamfered nuts, or shall be either indented or embossed on the non-bearing face of washer faced nuts.

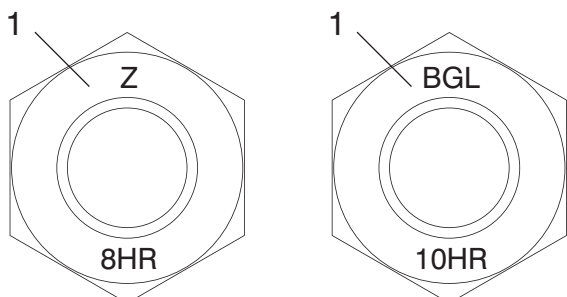

Key

1 Identification mark of the manufacturer of the Assembly

Normative References

The following documents, in whole or in part, are normatively referenced in this document and are indispensable for its application. For dated references, only the edition cited applies. For undated references, the latest edition of the referenced document (including any amendments) applies.

BS EN 14399-1, High-strength structural bolting assemblies for preloading - Part 1: General requirements

BS EN 14399-2, High-strength structural bolting assemblies for preloading - Part 2: Suitability for preloading

BS EN 14399-5, High-strength structural bolting assemblies for preloading - Part 5: Plain washers

BS EN 14399-6, High-strength structural bolting assemblies for preloading - Part 6: Plain chamfered washers

BS EN 14399-9, High-strength structural bolting assemblies for preloading - Part 9: System HR or HV
- Direct tension indicators for bolt and nut assemblies

BS EN 26157-1, Fasteners - Surface discontinuities - Part 1: Bolts, screws and studs for general requirements (ISO 6157-1)

BS EN ISO 898-1, Mechanical properties of fasteners made of carbon steel and alloy steel
- Part 1: Bolts, screws and studs with specified property classes - Coarse thread and fine pitch thread (ISO 898-1)

BS EN ISO 898-2, Mechanical properties of fasteners made of carbon steel and alloy steel
- Part 2: Nuts with specified property classes - Coarse thread and fine pitch thread (ISO 898-2)

BS EN ISO 3269, Fasteners - Acceptance inspection (ISO 3269)

BS EN ISO 4759-1, Tolerances for fasteners - Part 1: Bolts, screws, studs and nuts - Product grades A, B and C

BS EN ISO 6157-2, Fasteners - Surface discontinuities - Part 2: Nuts (ISO 6157-2)

BS EN ISO 10684, Fasteners - Hot dip galvanized coatings (ISO 10684)

ISO 261, ISO general purpose metric screw threads - General plan

ISO 965-2, ISO general purpose metric screw threads - Tolerances
- Part 2: Limits of sizes for general purpose external and internal screw threads - Medium quality

ISO 965-5, ISO general purpose metric screw threads - Tolerances - Part 5: Limits of sizes for internal screw threads to mate with hot-dip galvanized external screw threads with maximum size of tolerance position h before galvanizing

ISO 3508, Thread run-outs for fasteners with thread in accordance with ISO 261 and ISO 262

MANUFACTURERS OF HIGH INTEGRITY BOLTING ASSEMBLIES FOR WORLDWIDE STRUCTURAL ENGINEERING PROJECTS

BARNSLEY
01226 388444
sales@bappbarnsley.co.uk

LEEDS
01132 439600
sales@bappleeds.co.uk

ROCHDALE
01706 359500
sales@bapproch.co.uk

EXPORT
+44 (0)1226 394017
export@bappgroup.co.uk

BRIGHOUSE
01484 710531
sales@bappbrighouse.co.uk

LEICESTERSHIRE
01162 841888
sales@bappleicester.co.uk

SCUNTHORPE
01724 282112
sales@bappscunthorpe.co.uk

HEAD OFFICE
+44 (0)1226 383824
enquiries@bappgroup.co.uk

DONCASTER
01302 364444
sales@bappdon.co.uk

MANSFIELD
01623 751558
sales@bappmansfield.co.uk

WEST MIDLANDS
01215 259232
sales@bappwestmidlands.co.uk

TECHNICAL
+44 (0)7894 000204
technical@bappgroup.co.uk

HULL
01482 329797
sales@bapphull.co.uk

PRESTON
01772 704700
sales@bapppreston.co.uk

UK
01226 380902
sales@bappuk.co.uk



www.bapp.co.uk