

HIGH-STRENGTH STRUCTURAL
BOLTING ASSEMBLIES
FOR PRELOADING
BS EN 14399-6:2015
PLAIN CHAMFERED WASHERS



EN14399-1
Cert No:
0038/CPR/4006773/B



BAPP

Group of Companies

Dimensions

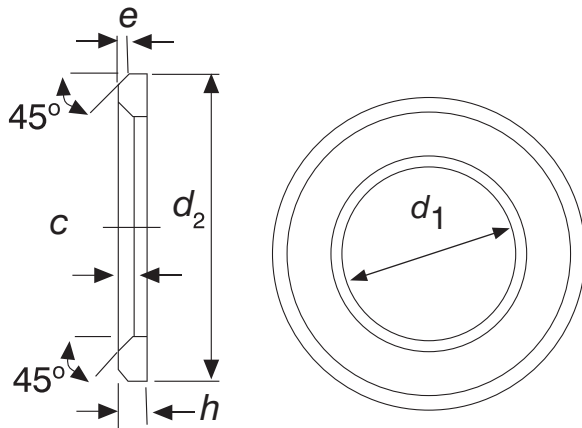

For coated washers the below dimensions apply prior to coating

Nominal size d (nominal thread diameter of associated bolt)		12	(14) ^a	16	(18) ^a	20	22	24	27	30	36
d_1	min.	13	15	17	19	21	23	25	28	31	37
	max.	13,27	15,27	17,27	19,33	21,33	23,33	25,33	28,52	31,62	37,62
d_2	min.	23,48	27,48	29,48	33,38	36,38	38,38	43,38	49,00	54,80	64,80
	max.	24	28	30	34	37	39	44	50	56	66
h	nom.	3	3	4	4	4	4	4	5	5	6
	min.	2,7	2,7	3,7	3,7	3,7	3,7	3,7	4,4	4,4	5,4
	max.	3,3	3,3	4,3	4,3	4,3	4,3	4,3	5,6	5,6	6,6
e	nom. = min.	0,5	0,5	0,75	0,75	0,75	0,75	0,75	1	1	1,25
	max.	1,0	1,0	1,5	1,5	1,5	1,5	1,5	2,0	2,0	2,5
c	min.	1,6	1,6	1,6	2,0	2,0	2,0	2,0	2,5	2,5	2,5
	max.	1,9	1,9	1,9	2,5	2,5	2,5	2,5	3,0	3,0	3,0

^a Sizes in brackets are non-preferred sizes.

Specifications & Reference Standards

Material		Steel
General requirements		BS EN 14399-1 and BS EN 14399-2
Mechanical properties	Hardness range	300 HV to 370 HV
Tolerances	Product grade	A
	European Standard	BS EN ISO 4759-3
Finish - Coating ^a	Uncoated	as processed ^b
	Hot dip galvanized	BS EN ISO 10684
	Others	to be agreed ^c
Workmanship		Parts shall be uniform and free of irregularities or detrimental defects. No protruding burrs shall appear on the washer.
Acceptability		For acceptance procedure, see BS EN ISO 3269.
^a Attention is drawn to the need to consider the risk of hydrogen embrittlement when selecting an appropriate surface treatment process (e.g. cleaning and coating), see relevant coating standards.		
^b "As processed" means the normal finish resulting from heat treatment with a light coating of oil.		
^c Other coatings may be negotiated between the purchaser and the manufacturer provided they do not impair the mechanical properties or the functional characteristics. Coatings of cadmium or cadmium alloys are not permitted.		

Marking

Hardened and tempered chamfered washers shall be marked with at least the manufacturer's trade (identification) mark and the letter H.

The manufacturer may decide to mark washers with HR or HV (instead of H marking) when they are supplied as component of bolting assemblies of system HR or HV respectively.

The marking shall be indented on the non-chamfered side.

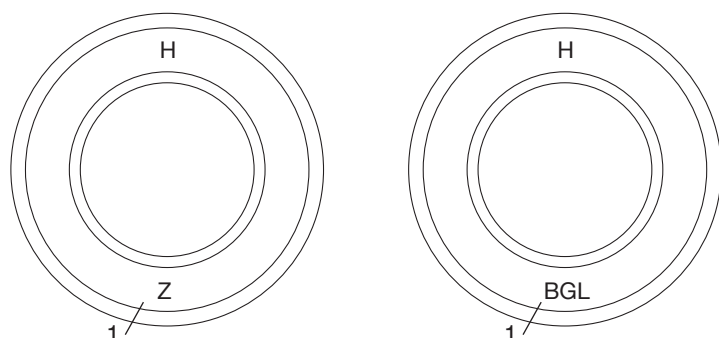

Key

1 identification mark of the manufacturer of the assembly

Normative References

The following documents, in whole or in part, are normatively referenced in this document and are indispensable for its application. For dated references, only the edition cited applies. For undated references, the latest edition of the referenced document (including any amendments) applies.

BS EN 14399-1, High-strength structural bolting assemblies for preloading - Part 1: General requirements

BS EN 14399-2, High-strength structural bolting assemblies for preloading - Part 2: Suitability for preloading

BS EN ISO 3269, Fasteners - Acceptance inspection (ISO 3269)

BS EN ISO 4759-3, Tolerances for fasteners - Part 3: Plain washers for bolts, screws and nuts - Products grades A and C (ISO 4759-3)

BS EN ISO 10684, Fasteners - Hot dip galvanized coatings (ISO 10684)

MANUFACTURERS OF HIGH INTEGRITY BOLTING ASSEMBLIES FOR WORLDWIDE STRUCTURAL ENGINEERING PROJECTS

BARNSELY
01226 388444
sales@bappbarnsley.co.uk

LEEDS
01132 439600
sales@bappleeds.co.uk

ROCHDALE
01706 359500
sales@bapproch.co.uk

EXPORT
+44 (0)1226 394017
export@bappgroup.co.uk

BRIGHOUSE
01484 710531
sales@bappbrighouse.co.uk

LEICESTERSHIRE
01162 841888
sales@bappleicester.co.uk

SCUNTHORPE
01724 282112
sales@bappscunthorpe.co.uk

HEAD OFFICE
+44 (0)1226 383824
enquiries@bappgroup.co.uk

DONCASTER
01302 364444
sales@bappdon.co.uk

MANSFIELD
01623 751558
sales@bappmansfield.co.uk

WEST MIDLANDS
01215 259232
sales@bappwestmidlands.co.uk

TECHNICAL
+44 (0)7894 000204
technical@bappgroup.co.uk

HULL
01482 329797
sales@bapphull.co.uk

PRESTON
01772 704700
sales@bapppreston.co.uk

UK
01226 380902
sales@bappuk.co.uk



www.bapp.co.uk