

Peg Anchor

FITTING GUIDE

THE BOLT
HAS BEEN
REBORN

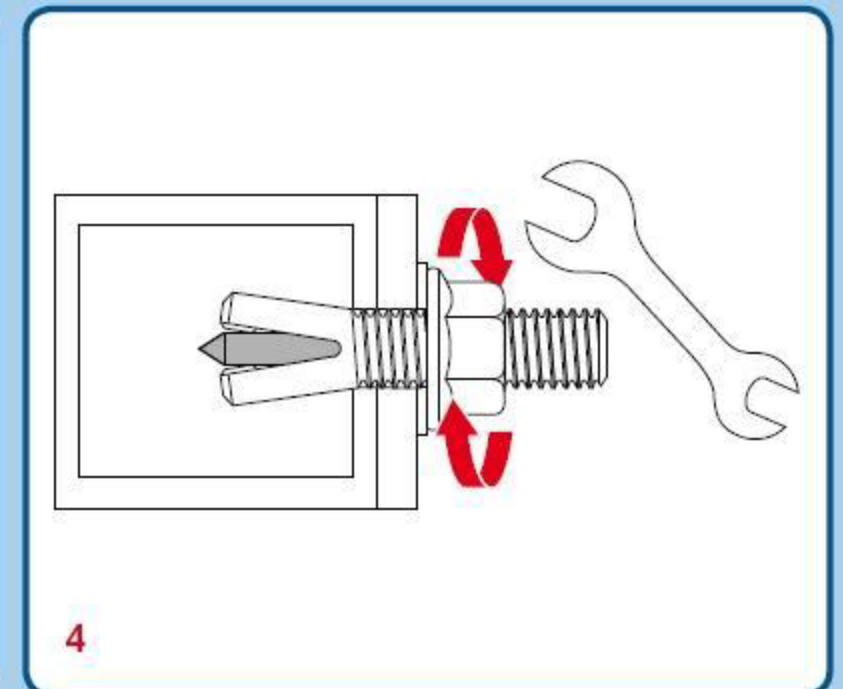
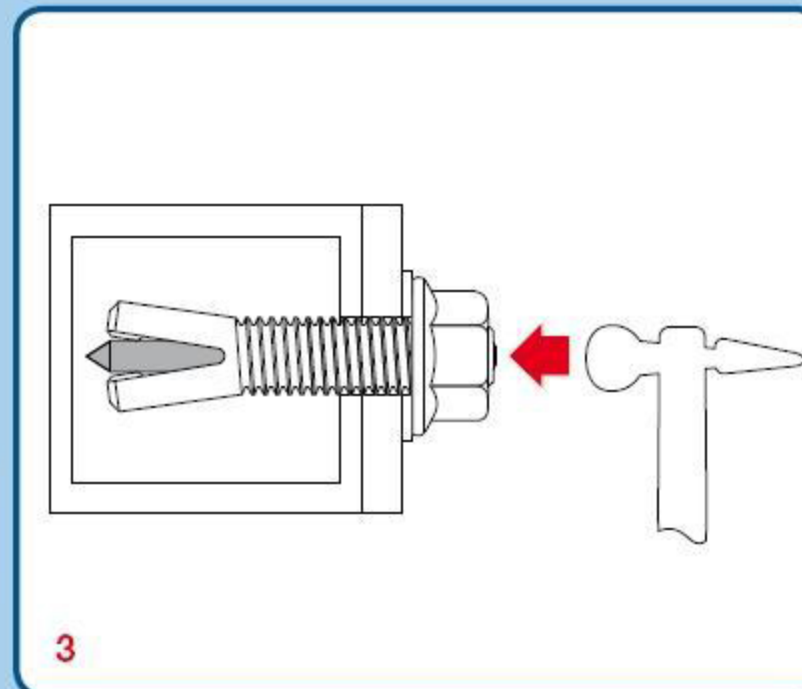
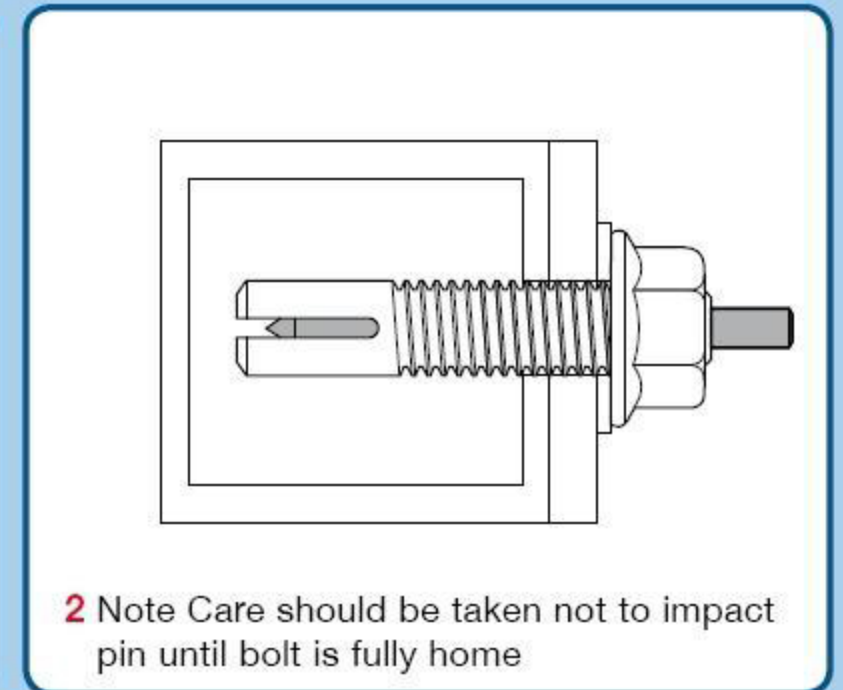
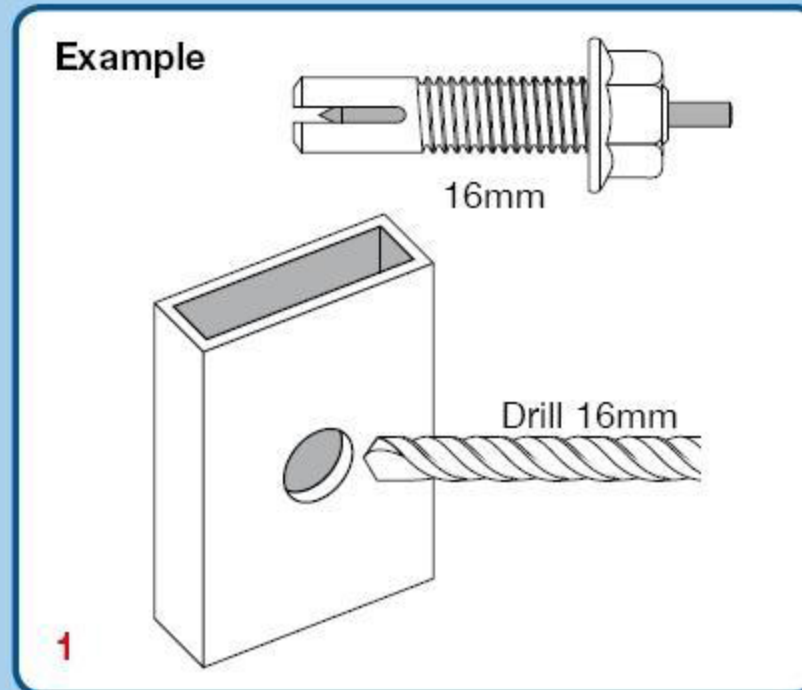

Mola Peg Anchor Fitting Guide

1. Locate nut at top of stud
2. Insert into hole, allowing slotted section to pass through hole
3. Strike pin home
4. Torque to ABS recommendations

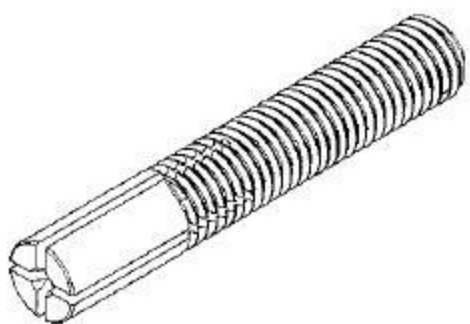
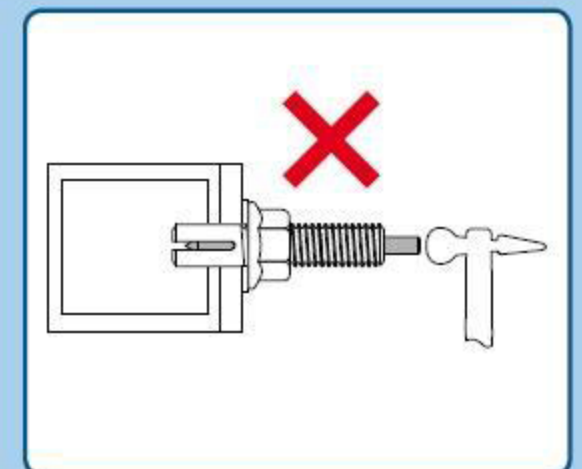

SIZE	GRADE	FINISH	PRODUCT CODE	CLAMPING RANG		TORQUE
				Min (mm)	Max (mm)	
M8 x 50	8.8	Zinc/Clear	PA0850	5	34	1.5
M10 x 50	8.8	Zinc/Clear	PA1050	5	30	35
M12 x 60	8.8	Zinc/Clear	PA1260	7	36	50
M16 x 60	8.8	Zinc/Clear	PA1660	7	32	100
M20 x 75	8.8	Zinc/Clear	PA2075	0	35	125